

★ Manufacturing Location

★ Sales Office/Agency



SHINAGAWA



REFRATORIES
FOR THE
HEAVY CLAY INDUSTRY



GLOBAL PROVIDER OF THERMAL SOLUTIONS

Shinagawa is the largest manufacturer and supplier of refractories in Australasia. To complement our extensive range of products we are able to supply materials to the heavy clay industry, including both the kiln lining and kiln car furniture. Our high quality kiln car furniture brick are manufactured from cordierite-mullite to AS1618 - 2003 and include:

- VIADUCT BLOCKS
- FLUE BLOCKS
- SETTING BLOCKS
- PERIMETER BLOCKS
- DECK TILES

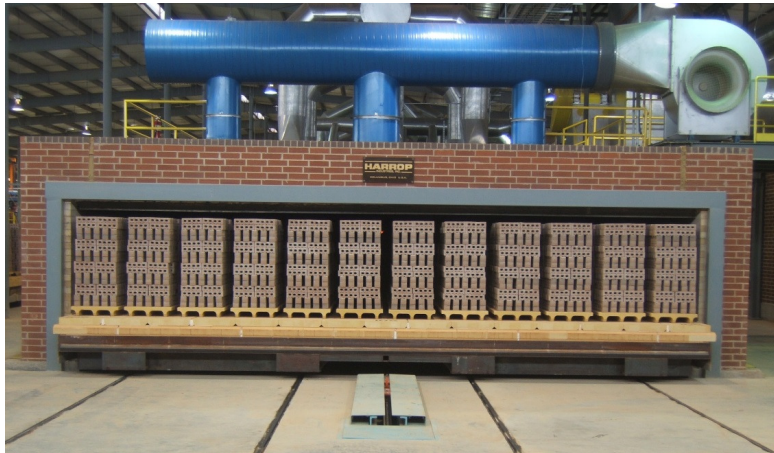

Design and Product Management

Shinagawa's experienced Engineers especially in regard to kiln firing technology, have the ability to design individual shapes as well as complete kiln car modifications using the latest CAD technology.

Our technical and financial resources enables us to adapt to any customer purchasing needs to suit any planned maintenance schedule requirements.

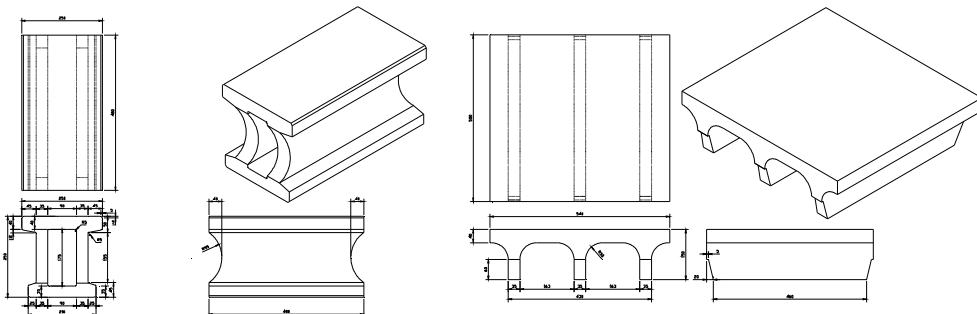

Kiln Car Furniture

Shinagawa currently offers two cordierite-mullite grades specifically designed for the manufacture of high quality kiln car furniture, depending on the operating environment of the kiln. Typical properties for each are listed below.

DECK BLOCK A

Bulk Density	2100 kg/m ³
Apparent Porosity	20%
Refractoriness:	1410°C
Chemistry (%): Al ₂ O ₃	48
SiO ₂	43
Fe ₂ O ₃	0.8
TiO ₂	0.4
CaO	0.5
MgO	5.6

DECK BLOCK B

Bulk Density:	2000 kg/m ³
Apparent Porosity:	24%
Refractoriness:	1300°C
Chemistry (%): Al ₂ O ₃	46
SiO ₂	43
Fe ₂ O ₃	1.3
TiO ₂	0.5
CaO	0.5
MgO	7.9



Other Products

With local manufacturing and storage facilities Shinagawa can also supply the following products:

- ALUMINO-SILICATE BRICK
- REFRACTORY CASTABLES
- CERAMIC FIBRES
- CALCIUM SILICATE
- LW INSULATION INFILL
- VERMICULITE
- HEATSET & AIRSET MORTARS



A full range of product installation recommendations and dry out curves are available for the Shinagawa range of products.